

NC-Cap/PSR™ (Primary Side Regulation) CV/CC Power Switch

FEATURES

- ◆ Built-in 700V Power BJT
- ◆ Proprietary NC-Cap/PSR™ Control
- ◆ Audio Noise Free Operation
- ◆ Proprietary “Smart Output Short Protection”
- ◆ 11.7V UVLO Hysteresis Window
- ◆ Proprietary “Zero-Output Startup” Control
- ◆ FB Short Protection
- ◆ Proprietary Cable Drop Compensation
- ◆ ±5% CC and CV Precision
- ◆ Low Standby Power Under 70mW
- ◆ Wide VDD Operating Range (7V to 24V)
- ◆ Compensate for Transformer Inductance Tolerances and Line Voltage Variation
- ◆ Pin Floating Protection
- ◆ Cycle-by-Cycle Current Limiting
- ◆ Built-in Leading Edge Blanking (LEB)
- ◆ Built-in Soft Start
- ◆ Output Over Voltage Protection
- ◆ VDD UVLO, OVP & Clamp

APPLICATIONS

- ◆ Battery chargers for cellular phones, cordless phones, PDA, digital cameras, etc
- ◆ Replaces linear transformer and RCC SMPS
- ◆ AC/DC LED lighting

GENERAL DESCRIPTION

SF6072 is a high precision, highly integrated DCM (Discontinuous Conduction Mode) Primary Side Regulation (PSR) power switch for offline small power converter applications. It has built-in power BJT, which can further lower system cost.

SF6072 has built-in proprietary **NC-Cap/PSR™** control for CV control, which eliminates external compensation or filtering capacitor. It has built-in cable drop compensation function, which can provide excellent CV performance. The IC uses Multi Mode Control to improve efficiency and reliability and to decrease audio noise energy @ light loadings. The IC can achieve less than 70mW standby power.

SF6072 integrates proprietary **“Zero-Output Startup”** control to achieve startup when output is near zero voltage. The IC also has proprietary **“Smart Output Short Protection”**, which can limit maximum power when output is short circuit.

SF6072 integrates functions and protections of FB Short Protection, Under Voltage Lockout (UVLO), VDD Over Voltage Protection (VDD OVP), Output Over Voltage Protection (Output OVP), Soft Start, Cycle-by-cycle Current Limiting (OCP), Pin Floating Protection, VDD Clamping.

SF6072 is available in SOIC-7 and SOP8 packages.

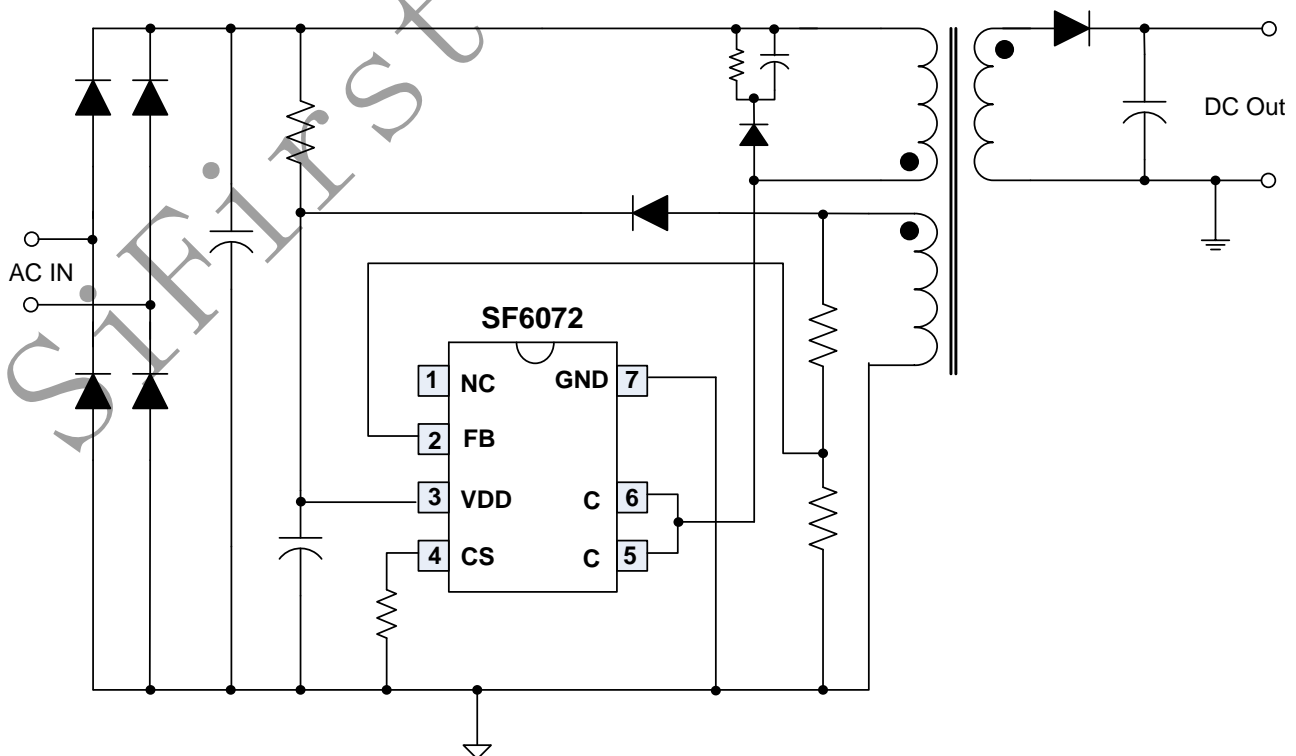
TYPICAL APPLICATION

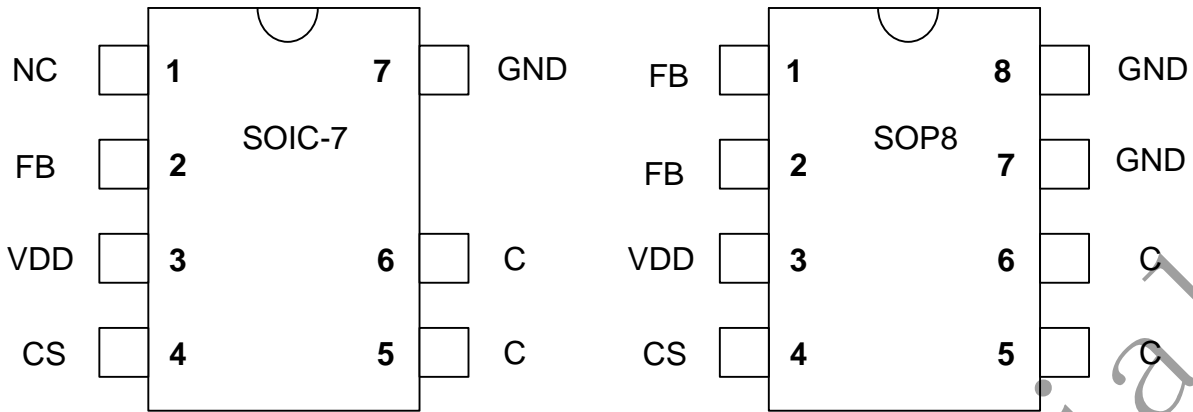
Pin Configuration

Ordering Information

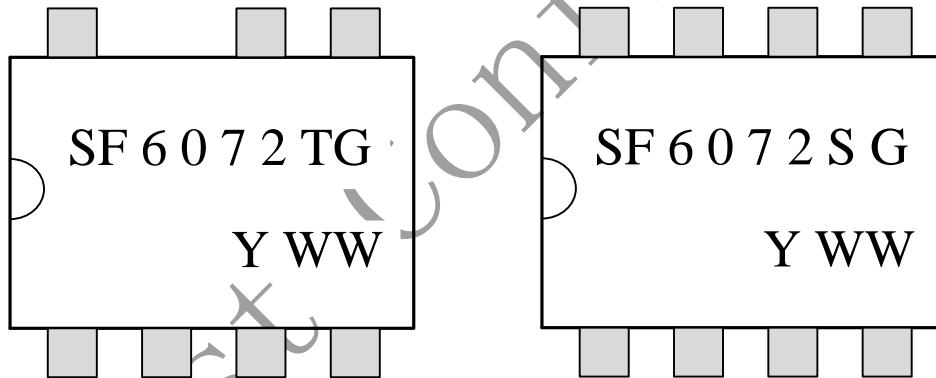
Part Number	Top Mark	Package		Tape & Reel
SF6072TG	SF6072TG	SOIC-7	Green	
SF6072TGT	SF6072TG	SOIC-7	Green	Yes
SF6072SG	SF6072SG	SOP8	Green	
SF6072SGT	SF6072SG	SOP8	Green	Yes

Marking Information

YWW: Year&Week code

Pin Description

Pin Num	Pin Name	I/O	Description
1	NC	-	No connect. If SOP8 package, this pin is connected with pin FB
2	FB	I	System feedback pin. This control input regulates both the output voltage in CV mode and output current in CC mode based on the flyback voltage of the auxiliary winding.
3	VDD	P	IC power supply pin.
4	CS	I	Current sense pin.
5-6	C	P	High voltage power BJT collector pin.
7	GND	P	Ground

Output Power Table⁽¹⁾

Part Number	230VAC \pm 15% ⁽²⁾	85-265VAC
	Adapter ⁽³⁾	Adapter ⁽³⁾
SF6072	6.5W	4.5W

Note 1. The Max. output power is limited by junction temperature

Note 2. 230VAC or 100/115VAC with doublers

Note 3. Typical continuous power in a non-ventilated enclosed adapter with sufficient drain pattern as a heat sink at 50°C ambient.

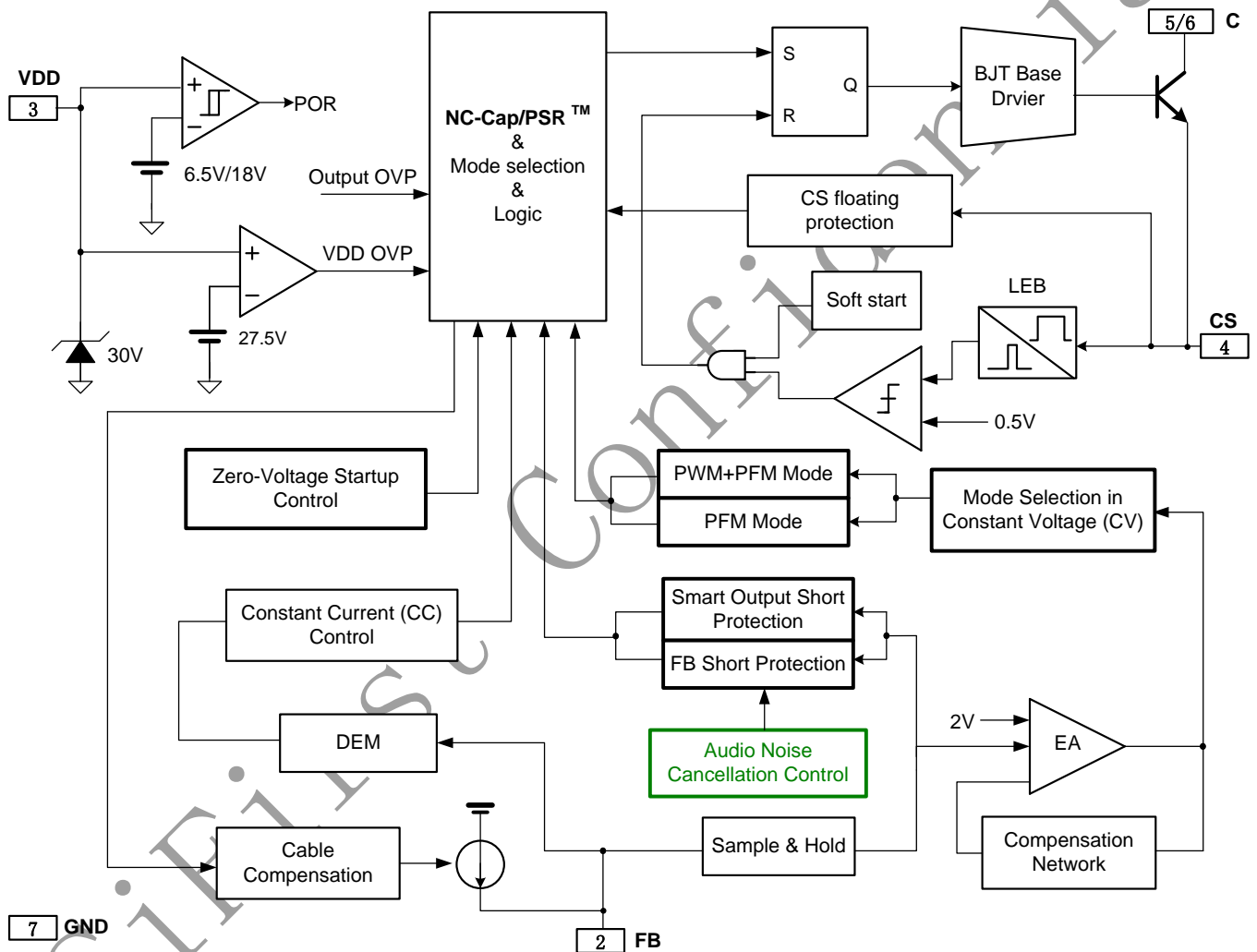
Block Diagram

Recommended Operation Conditions (Note 4)

Parameter	Value	Unit
Supply Voltage, VDD	7 to 24	V
Operating Ambient Temperature	-40 to 85	°C
Maximum Switching Frequency	70K	Hz

Absolute Maximum Ratings (Note 5)

Parameter	Value	Unit
VDD DC Supply Voltage	30.5	V
VDD DC Clamp Current	10	mA
CS, BASE voltage range	-0.3 to 7	V
FB voltage range	-0.7 to 7	V
Collector to Emitter Voltage	700	V
Package Thermal Resistance (SOIC-7)	150	°C/W
Package Thermal Resistance (SOP-8)	150	°C/W
Maximum Junction Temperature	150	°C
Operating Temperature Range	-40 to 85	°C
Storage Temperature Range	-65 to 150	°C
Lead Temperature (Soldering, 10sec.)	260	°C
ESD Capability, HBM (Human Body Model)	3	kV
ESD Capability, MM (Machine Model)	250	V

ELECTRICAL CHARACTERISTICS

 (T_A = 25°C, VDD=18V, if not otherwise noted)

Symbol	Parameter	Test Conditions	Min	Typ	Max	Unit
Supply Voltage (VDD) Section						
I_Startup	VDD Start up Current	VDD =UVLO(ON)-1V, Measure current into VDD		3	20	uA
I_VDD_Op	Operation Current			0.6	1.5	mA
UVLO(ON)	VDD Under Voltage Lockout Enter		16.5	18	19.5	V
UVLO(OFF)	VDD Under Voltage Lockout Exit		5.5	6.5	7	V
VDD_OVP	VDD Over Voltage Protection trigger		25	27.5	30	V
V _{DD} _Clamp	VDD Zener Clamp Voltage	I(V _{DD}) = 10 mA	28	30	32	V
T_Softstart	Soft Start Time			2		mSec
Feedback Input Section(FB Pin)						
V _{FB_EA_Ref}	Internal Error Amplifier(EA) reference input		1.98	2.0	2.02	V
V _{FB_DEM}	Demagnetization comparator threshold			25		mV
T _{min_OFF}	Minimum OFF time			2		uSec
T _{max_OFF}	Maximum OFF time			5		mSec
V _{FB_Short}	Output Short Circuit Threshold			0.6		V
T _{FB_Short}	Output Short Circuit Debounce Time			13		mSec
T _{CC} /T _{DEM}	Ratio between switching period in CC mode and demagnetization time			2		
I _{Cable_max}	Max Cable compensation current			60		uA
Current Sense Input Section (CS Pin)						
T _{blanking}	CS Input Leading Edge Blanking Time			500		nSec
V _{th_OC_max}	Max. Current limiting threshold		490	500	510	mV

T _{D_OC}	Over Current Detection and Control Delay			100		nSec
Power BJT Section						
V _{CEO}	Collector-emitter breakdown voltage	I _c =10mA, I _b =0	450			V
V _{CB0}	Collector- base breakdown voltage	I _c =10mA	700			V
H _{fe}	DC current gain	V _{ce} =5V, I _c =0.5A	10		40	
V _{CE_sat}	Collector-emitter saturation voltage	I _c =0.5A, I _b =0.1A			0.5	V

Note 4. The device is not guaranteed to function outside its operating conditions.

Note 5. Stresses beyond those listed under “Absolute Maximum Ratings” may cause permanent damage to the device. These are stress ratings only, and functional operation of the device at these or any other conditions beyond those indicated in the operational sections of the specifications is not implied. Exposure to absolute maximum rating conditions for extended periods may affect device reliability.

CHARACTERIZATION PLOTS

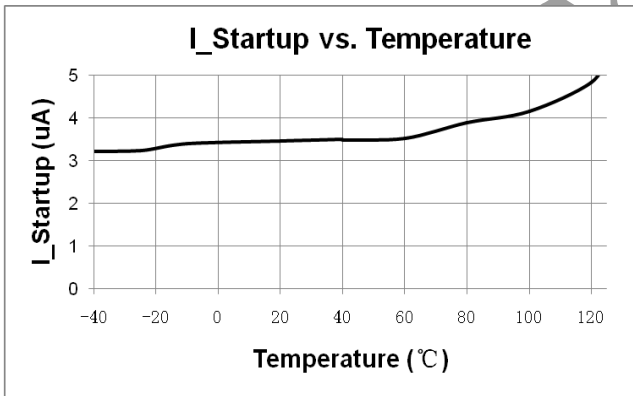
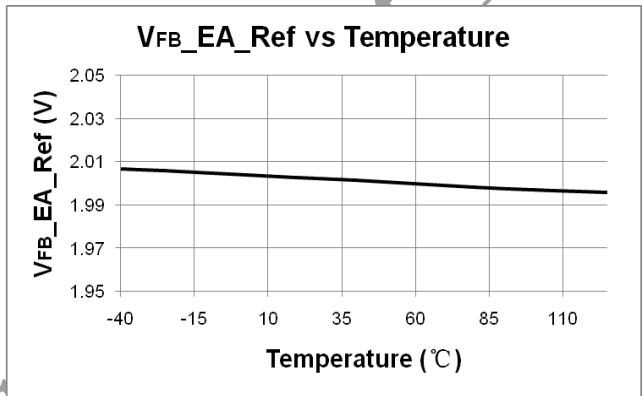
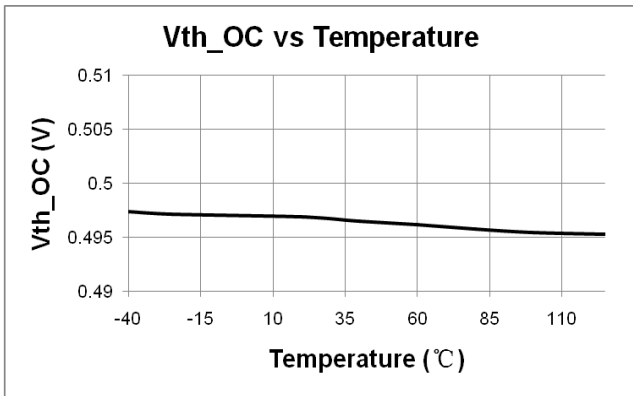
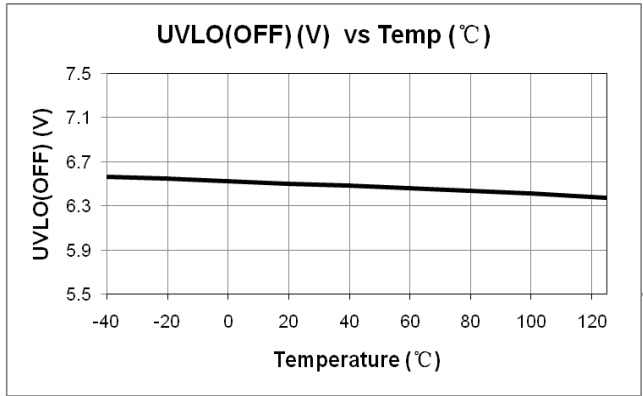
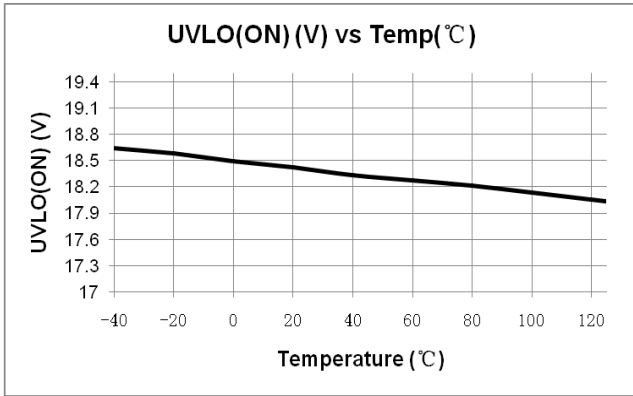

OPERATION DESCRIPTION

SF6072 is a high performance, highly integrated DCM (Discontinuous Conduction Mode) Primary Side Regulation (PSR) power switch. The built-in high precision CV/CC control makes it very suitable for offline small power converter applications.

◆ PSR Technology Introduction

Assuming the system works in DCM mode, the power transfer function is given by

$$P = \frac{\eta}{2} \times L_m \times I_{pk}^2 \times f_s = V_o \times I_o \quad (\text{Eq.1})$$

In the equation above, P is output power, Vo and Io are system output voltage and current respectively, η is system power transfer efficiency, Lm is transformer primary inductance, fs is system switching frequency, Ipk is primary peak current in a switching cycle. The following figure illustrates the waveform in a switching cycle.

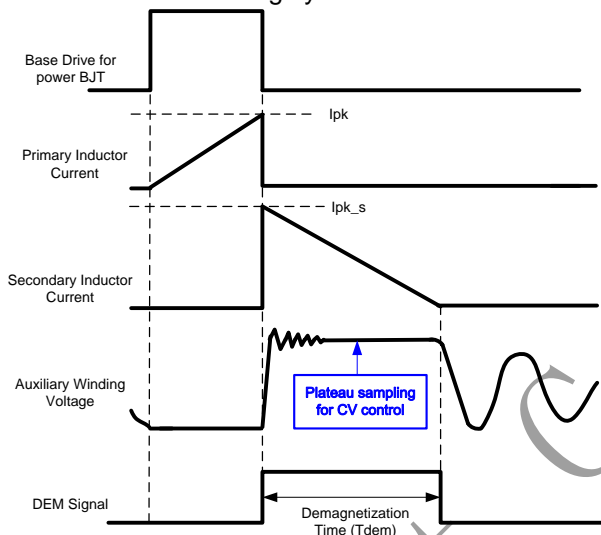

Fig.1

In the figure shown above, the IC generates a demagnetization signal (DEM) in each switching cycle through auxiliary winding. Tdem is demagnetization time for CV/CC control. In DCM mode, Tdem can be expressed as;

$$\frac{V_p}{L_m} \times T_{dem} = \frac{N_s}{N_p} \times I_{pk} \quad (\text{Eq.2})$$

In Eq.2, Np and Ns are primary and secondary winding turns respectively.

Combined with Eq.1 and Eq. 2, the average output current can be expressed as:

$$I_o = \frac{\eta}{2} \times I_{pk} \times \frac{N_p}{N_s} \times f_s \times T_{dem} \quad (\text{Eq.3})$$

CC (Constant Current) Control Scheme

From Eq.3, it can be easily seen that there are two ways to implement CC control: one is PFM (Pulse Frequency Modulation), the control scheme is to keep Ipk to be constant, let the product of Ts and Tdem (fs*Tdem) to be a constant. In this way, Io

will be a value independent to the variation of Vo, Lm, and line input voltage. Another realization method is PWM duty control, the control scheme is to keep fs to be constant, let the product of Tdem and Ipk (Tdem*Ipk) to be a constant, in another words, by modulating system duty cycle to realize a constant Io independent to the variation of Vo, Lm and line voltages.

SF6072 adopts PFM for CC control, the product of Ts and Tdem is given by

$$f_s \times T_{dem} = 0.5 \quad (\text{Eq.4})$$

CV (Constant Voltage) Control Scheme

CV control should sample the plateau of auxiliary winding voltage in flyback phase, as shown in Fig.1 The CV control has many implementations, for example, PWM, or PFM, or a combination of both one. In SF6072, the CV control adopts proprietary multi mode control, as mention below.

◆ Startup Current / Startup Control / Operating Current

Startup current of SF6072 is designed to be very low (typically 3uA) so that VDD could be charged up above UVLO(ON) threshold level and device starts up quickly. The operating current in SF6072 is as small as 0.8mA (typical). The small operating current results in higher efficiency and reduces the VDD hold-up capacitance requirement.

◆ NC-Cap/PSR™ Eliminates External Compensation/Filtering Capacitor

SF6072 uses a proprietary control to eliminate external compensation capacitor, which can simplify system design and lower system cost.

◆ Proprietary Cable Drop Compensation

SF6072 has a proprietary built-in cable voltage drop compensation block which can provide a constant output voltage at the end of the cable over the entire load range in CV mode.

◆ Precision CV/CC Performance

In SF6072, the parameters are trimmed to tight range, which makes the system CC/CV to have less than 5% variation.

◆ Proprietary “Audio Noise Cancellation” Control

SF6072 has a proprietary “Audio Noise Cancellation” control, which can achieve audio noise free operation in the whole loading range.

◆ Soft Start

SF6072 features an internal 2ms (typical) soft start that slowly increases the threshold of cycle-by-cycle current limiting comparator during startup sequence. Every startup process is followed by a soft start activation.

◆ **Multi Mode PSR Control for High Reliability , High Efficiency, and Audio Noise Free Operation**

Conventional pure PFM controlled PSR system may suffer transformer saturation issue when heavy loading. In SF6072, a proprietary multi mode control is adopted to suppress this issue, as shown in Fig.2. Around the full load, the system operates in PWM+PFM mode, which improve the system reliability. Under normal to light load conditions, the IC operates in PFM mode to achieve excellent regulation and high efficiency. Multi mode control can also reduce audio noise in lighting loadings, compared to conventional pure PFM control.

◆ **Zero-Output Startup Control**

Conventional PSR system may suffer startup failure when output voltage is near zero voltage, which means that there is a gap between OCP (CC point in PSR CV/CC system) and full loading. Larger OCP gap causes larger system cost. In SF6072, a proprietary “Zero-Output Startup Control” is adopted to achieve successful startup @ $V_{out}=0V$, as shown in Fig.2.

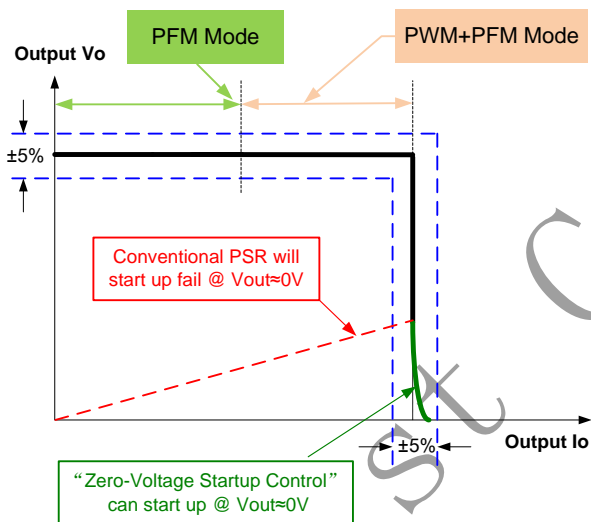

Fig.2

◆ **Leading Edge Blanking (LEB)**

Each time the power BJT is switched on, a turn-on spike occurs across the sensing resistor. To avoid premature termination of the switching pulse, an internal leading edge blanking circuit is built in. During this blanking period (500ns, typical), the cycle-by-cycle current limiting comparator is disabled and cannot switch off the base driver.

◆ **Minimum and Maximum OFF Time**

In SF6072, a minimum OFF time (typically 2us) is implemented to suppress ringing when BASE drive is pull off. The maximum OFF time in SF6072 is typically 5ms, which provides a large range for frequency reduction. In this way, a low standby power of 70mW can be achieved.

◆ **Pin Floating Protection**

In SF6072, if pin floating situation occurs, the IC is designed to have no damage to system.

◆ **Smart Output Short Protection**

The output short circuit protection of conventional PSR system is based on the coupling between auxiliary winding and secondary winding. When output is short, the auxiliary winding cannot provide enough energy to the IC any more. In this way, the system will enter into auto-recovery mode protection. However, the IC may be wrongly supplied if the leakage inductance of the primary winding is large enough.

In SF6072, if output short circuit occurs, the IC will detect the situation and enter into auto-recovery mode protection.

◆ **Built-in Load and AC Line CC Compensation**

In conventional PSR system, the output CC (Constant Current) point can vary with output and AC line voltage. In SF6072 the IC has built-in blocks to compensate the variation, as shown in Fig.3. The IC can adjust CC point based on sensed output voltage and PFM duty. In this way, CC accuracy can be improved.

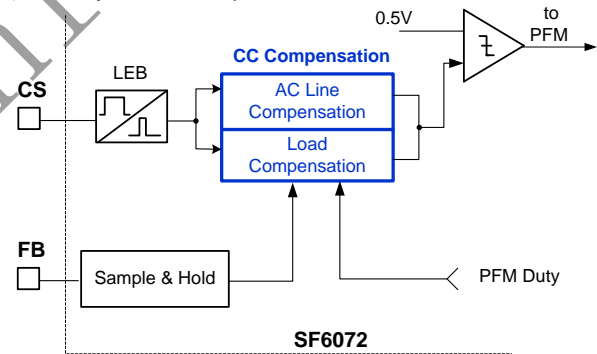

Fig.3

◆ **Auto Recovery Mode Protection**

As shown in Fig.4, once a fault condition is detected, switching will stop. This will cause VDD to fall because no power is delivered from the auxiliary winding. When VDD falls to UVLO(off) (typical 6.5V), the protection is reset and the operating current reduces to the startup current, which causes VDD to rise, as shown in Fig.4. However, if the fault still exists, the system will experience the above mentioned process. If the fault has gone, the system resumes normal operation. In this manner, the auto restart can alternatively enable and disable the switching until the fault condition is disappeared.

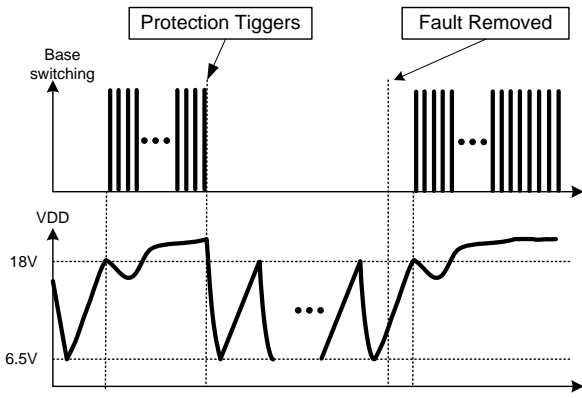

Fig.4

◆ **VDD OVP(Over Voltage Protection)**
 VDD OVP is implemented in SF6072 and it is a protection of auto-recovery mode.

SiFirst Confidential

PACKAGE MECHANICAL DATA

SOIC-7

Unit: mm(inch)

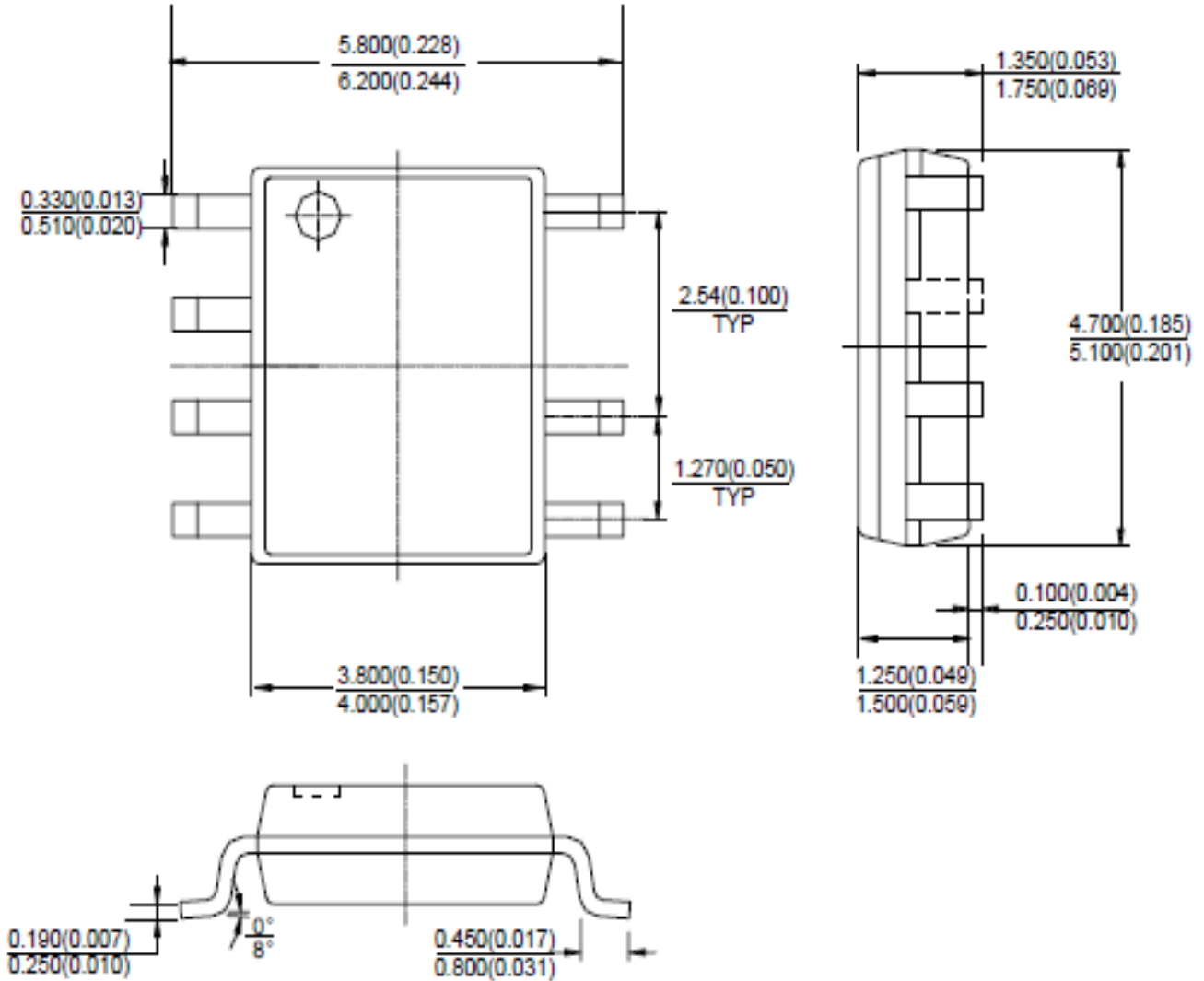

Note: Eject hole, oriented hole and mold mark is optional.

PACKAGE MECHANICAL DATA

SOP8 PACKAGE OUTLINE DIMENSIONS

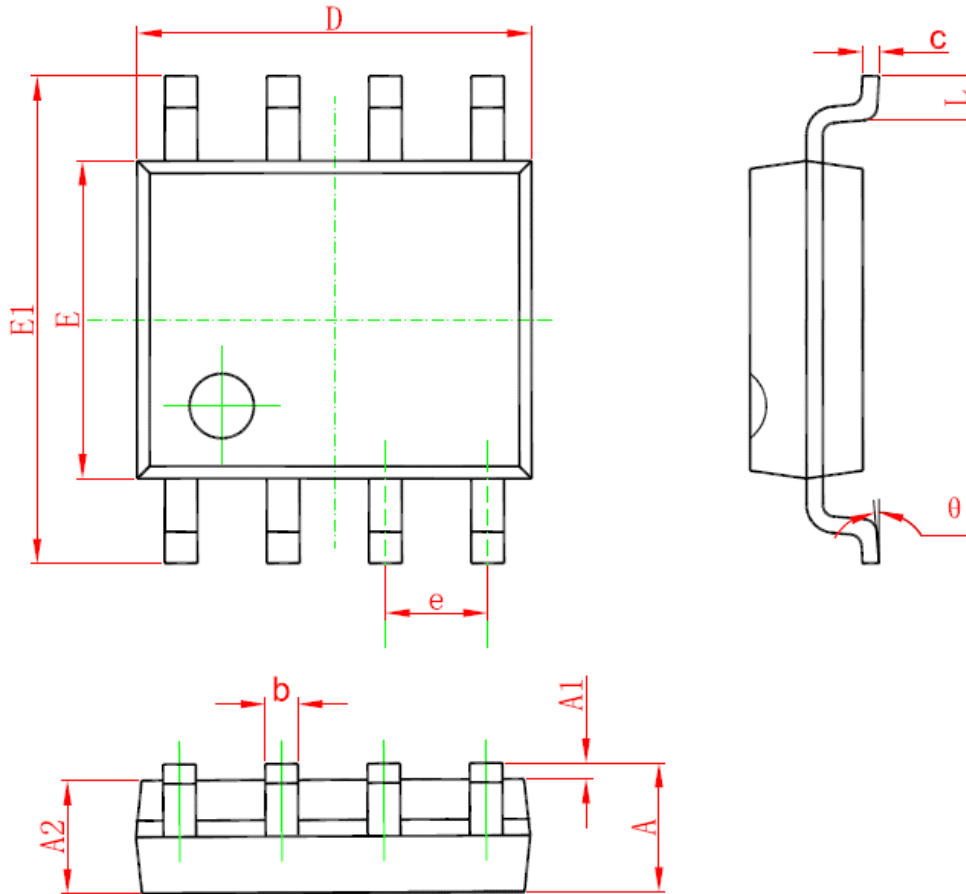

Symbol	Dimensions In Millimeters		Dimensions In Inches	
	Min	Max	Min	Max
A	1.350	1.750	0.053	0.069
A1	0.050	0.250	0.002	0.010
A2	1.250	1.650	0.049	0.065
b	0.310	0.510	0.012	0.020
c	0.170	0.250	0.006	0.010
D	4.700	5.150	0.185	0.203
E	3.800	4.000	0.150	0.157
E1	5.800	6.200	0.228	0.244
e	1.270 (BSC)		0.05 (BSC)	
L	0.400	1.270	0.016	0.050
θ	0°	8°	0°	8°

IMPORTANT NOTICE

SiFirst Technology Nanhai, Ltd (SiFirst) reserves the right to make corrections, modifications, enhancements, improvements and other changes to its products and services at any time and to discontinue any product or service without notice. Customers should obtain the latest relevant information before placing orders and should verify that such information is current and complete.

SiFirst warrants performance of its hardware products to the specifications applicable at the time of sale in accordance with SiFirst's standard warranty. Testing and other quality control techniques are used to the extent SiFirst deems necessary to support this warranty. Except where mandated by government requirements, testing of all parameters of each product is not necessarily performed.

SiFirst assumes no liability for application assistance or customer product design. Customers are responsible for their products and applications using SiFirst's components. To minimize the risks associated with customer products and applications, customers should provide adequate design and operating safeguards.

Reproduction of SiFirst's information in SiFirst's data books or data sheets is permissible only if reproduction is without alteration and is accompanied by all associated warranties, conditions, limitations, and notices. Reproduction of this information with alteration is an unfair and deceptive business practice. SiFirst is not responsible or liable for such altered documentation. Information of third parties may be subject to additional restrictions.

Resale of SiFirst's products or services with statements different from or beyond the parameters stated by SiFirst for that product or service voids all express and any implied warranties for the associated SiFirst's product or service and is an unfair and deceptive business practice. SiFirst is not responsible or liable for any such statements.

SiFirst's products are neither designed nor intended for use in military applications. SiFirst will not be held liable for any damages or claims resulting from the use of its products in military applications.

SiFirst's products are not designed to be used as components in devices intended to support or sustain human life. SiFirst will not be held liable for any damages or claims resulting from the use of its products in medical applications.