

Cost Effective, High Power, η -Balance™ PWM Controller

FEATURES

- ◆ 800mA Drive Capability, up to 100W Application with Low System Cost
- ◆ Proprietary η -Balance™ Control to Boost Light Load Efficiency
- ◆ Proprietary “Audio Noise Free OCP Compensation”
- ◆ Proprietary “Zero OCP/OPP Recovery Gap” Control
- ◆ Latch Plug-off Protection with External Triggering
- ◆ Fixed 65KHz Switching Frequency
- ◆ Built-in Soft Start Function
- ◆ Pins Floating Protection
- ◆ Current Mode Control
- ◆ Built-in Frequency Shuffling
- ◆ Built-in Synchronous Slope Compensation
- ◆ Cycle-by-Cycle Current Limiting
- ◆ Built-in Leading Edge Blanking (LEB)
- ◆ Constant Power Limiting
- ◆ Audio Noise Free Operation
- ◆ VDD UVLO, OVP & Clamp

APPLICATIONS

Offline AC/DC Flyback Converter for

- ◆ AC/DC Adaptors
- ◆ Open-frame SMPS
- ◆ Print Power, Scanners, and Motor Drivers

GENERAL DESCRIPTION

SF1585 is a high performance, cost effective, highly integrated current mode PWM controller for medium to large offline flyback power converter applications. In SF1585, PWM switching frequency with shuffling is fixed to 65KHz and is trimmed to tight range. When the output power demands decrease, the IC decreases switching frequency based on the proprietary η -Balance™ control to boost power conversion efficiency at the light load. When the current set-point falls below a given value, e.g. the output power demand diminishes, the IC enters into burst mode and provides excellent efficiency without audio noise.

SF1585 can achieve “Zero OCP/OPP Recovery Gap” using SiFirst’s proprietary control algorithm. It also has built in proprietary “Audio Noise Free OCP Compensation”, which can achieve constant power limiting and can achieve audio noise operation at heavy loading when line input is around 90VAC.

SF1585 integrates functions and protections of Under Voltage Lockout (UVLO), VCC Over Voltage Protection (OVP), Cycle-by-cycle Current Limiting (OCP), External Programmable Over Temperature Protection (OTP), All Pins Floating Protection, Over Load Protection (OLP), Gate Clamping, VCC Clamping, Leading Edge Blanking (LEB).

In SF1585, the OTP and VDD OVP is **Latch Plug-off** protection. The other protection functions are auto-recovery mode protection.

SF1585 is available in SOT23-6, DIP-8 packages.

TYPICAL APPLICATION

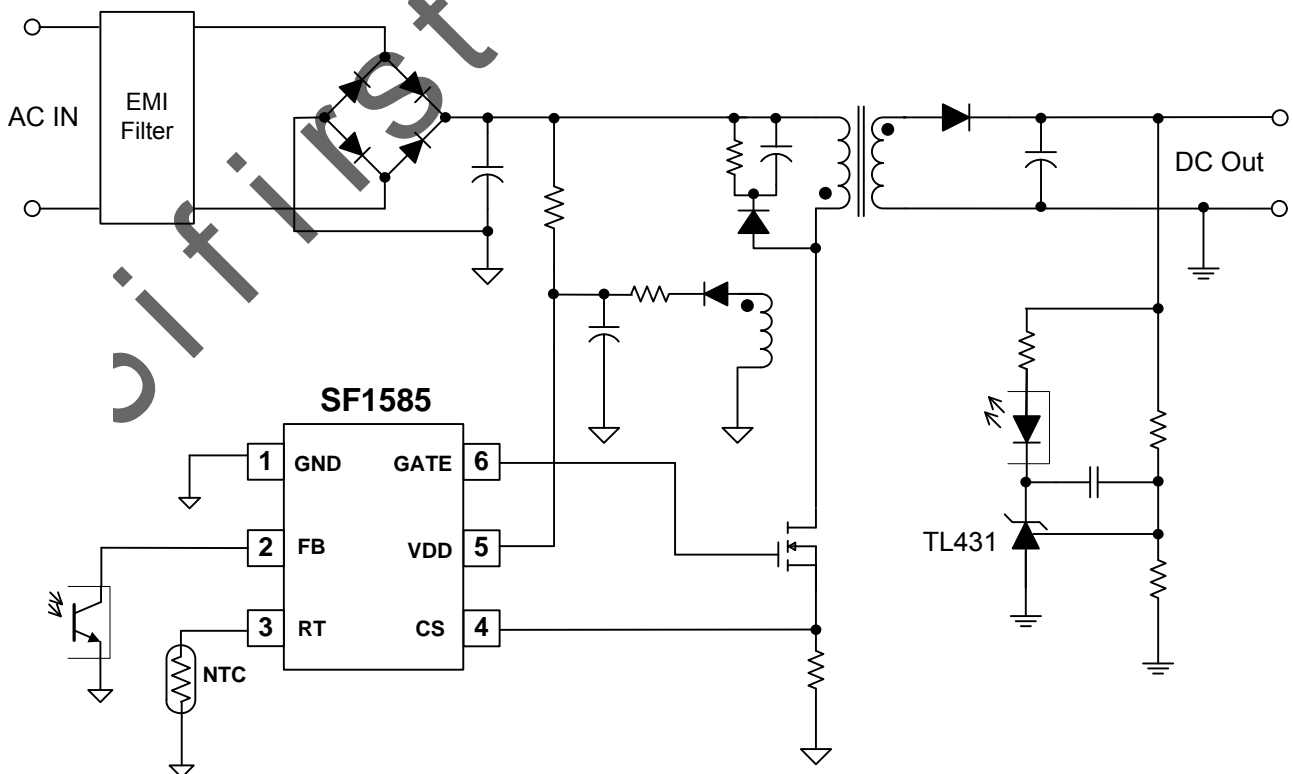

Pin Configuration

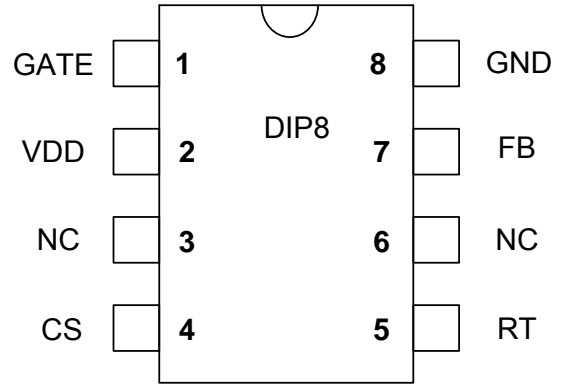
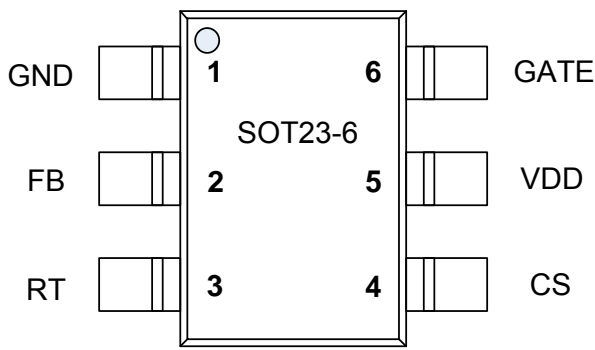

Ordering Information

Part Number	Top Mark	Package		Tape & Reel
SF1585LGT	.85YWW	SOT26	Green	Yes
SF1585DP	SF1585DP	DIP8	RoHS	

Marking Information

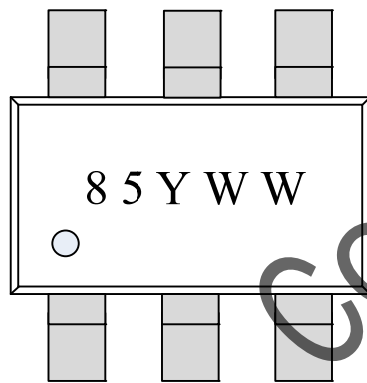

45: Part number SF1585
YWW: Year&Week Code

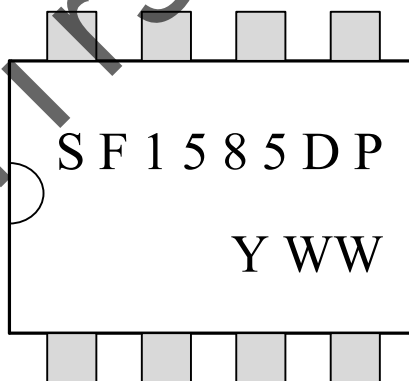

YWW: Year&Week code

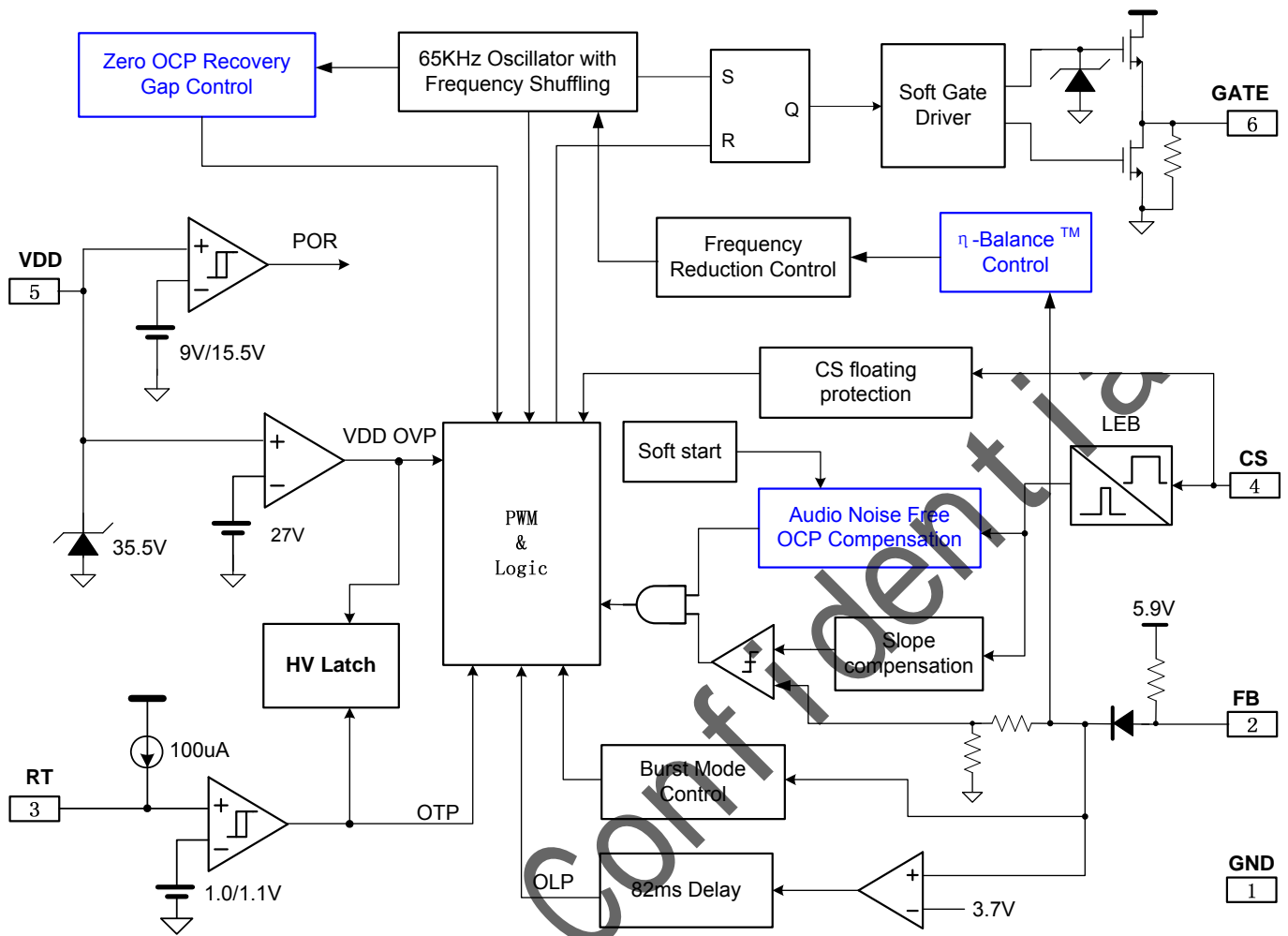
Block Diagram

Pin Description

Pin Num	Pin Name	I/O	Description
1	GND	P	Ground
2	FB	I	Voltage feedback pin. The loop regulation is achieved by connecting a photo-coupler to this pin. PWM duty cycle is determined by this pin voltage and the current sense signal at Pin 4.
3	RT	I	This pin is for over temperature protection by connecting an external NTC resistor to ground. Once the pin voltage drops below a fixed limit of 1.0V, PWM output will be disabled.
4	CS	I	Current sense input pin.
5	VDD	P	IC power supply pin.
6	GATE	O	Totem-pole gate driver output to drive the external MOSFET.

Absolute Maximum Ratings (Note 1)

Parameter	Value	Unit
VDD DC Supply Voltage	35	V
VCC DC Clamp Current	10	mA
GATE pin	20	V
FB, RT, CS voltage range	-0.3 to 7	V
Package Thermal Resistance (SOT-26)	250	°C/W
Package Thermal Resistance (DIP-8)	90	°C/W

Package Thermal Resistance (SOP-8)	150	°C/W
Maximum Junction Temperature	150	°C
Operating Temperature Range	-40 to 85	°C
Storage Temperature Range	-65 to 150	°C
Lead Temperature (Soldering, 10sec.)	260	°C
ESD Capability, HBM (Human Body Model)	3	kV
ESD Capability, MM (Machine Model)	250	V

Recommended Operation Conditions (Note 2)

Parameter	Value	Unit
Supply Voltage, VDD	11 to 25	V
Operating Frequency	50 to 130	kHz
Operating Ambient Temperature	-40 to 85	°C

ELECTRICAL CHARACTERISTICS

 (T_A = 25°C, VDD=18V, if not otherwise noted)

Symbol	Parameter	Test Conditions	Min	Typ	Max	Unit
Supply Voltage Section (VDD Pin)						
I_Startup	VDD Start up Current	VDD =UVLO(OFF)-1V, Measure current into VDD		3	15	uA
I_VDD_Op	Operation Current	V _{FB} =3V,GATE=1nF		2.7	4	mA
UVLO(ON)	VDD Under Voltage Lockout Exit (Startup)		14.5	15.5	16.5	V
UVLO(OFF)	VDD Under Voltage Lockout Enter		8	9	9.8	V
VDD_OVP	VDD Over Voltage Protection trigger		25	27	29	V
V _{DD} _Clamp	VDD Zener Clamp Voltage	I(V _{DD}) = 7mA	33.5	35.5	37.5	V
T_Softstart	Soft Start Time			4		mSec
Feedback Input Section(FB Pin)						
V _{FB} _Open	FB Open Voltage			5.9		V
I _{FB} _Short	FB short circuit current	Short FB pin to GND, measure current		1.2		mA
A _{VCS}	PWM Input Gain	$\Delta V_{FB} / \Delta V_{CS}$		1.6		V/V
V _{FB} _min_duty	FB under voltage gate clock is off.			1.0		V
V _{TH} _PL	Power Limiting FB Threshold Voltage			3.7		V
T _D _PL	Power limiting Debounce Time	Note 3		82		mSec
Z _{FB} _IN	Input Impedance			5		Kohm
Current Sense Input Section (CS Pin)						
V _{th} _OC_min	Internal current limiting threshold	Zero duty cycle	0.70	0.75	0.80	V
T_blanking	SENSE Input Leading Edge Blanking Time			250		nSec
T _D _OC	Over Current Detection and Control Delay	CL=1nF at GATE,		90		nSec
Oscillator Section						
F _{osc}	Normal Oscillation Frequency		60	65	70	KHZ
ΔF (shuffle)/Fosc	Frequency shuffling range	Note 4	-4		4	%
Δf _Temp	Frequency Temperature Stability	-20°C to 100 °C (Note 4)		5		%

Δf_{VDD}	Frequency Voltage Stability	VDD = 12-25V,		5		%
Duty_max	Maximum Duty cycle		75	80	85	%
F_BM	Burst Mode Base Frequency			22		KHZ
Over Temperature Protection (RT Pin)						
I_RT	Output Current of RT Pin		95	100	105	uA
VTH_OTP	OTP Threshold Voltage		0.95	1.0	1.05	V
VTH_OTP_OFF	OTP Release Voltage			1.1		V
VTH_OTP_Hys	OTP Hysteresis			0.1		V
V_RT_Open	RT Pin Open Voltage			4.6		V
Latch Protection						
V _{Latch_release}	VDD Latch Release Voltage		5.5	6	6.5	V
I _{vdd(latch)}	VDD Current when latch off	VDD= V _{Latch_release} +1V		40		uA
Gate Drive Output (GATE Pin)						
VOL	Output Low Level	I _o = 20 mA (sink)			0.3	V
VOH	Output High Level	I _o = 20 mA (source)	11			V
VG_Clamp	Output Clamp Voltage Level	VDD=24V		16		V
T _r	Output Rising Time	GATE = 1nF		100		nSec
T _f	Output Falling Time	GATE = 1nF		40		nSec

Note 1. Stresses beyond those listed under “Absolute Maximum Ratings” may cause permanent damage to the device. These are stress ratings only, and functional operation of the device at these or any other conditions beyond those indicated in the operational sections of the specifications is not implied. Exposure to absolute maximum rating conditions for extended periods may affect device reliability.

Note 2. The device is not guaranteed to function outside its operating conditions.

Note 3. The OLP debounce time is proportional to the period of switching cycle.

Note 4. Guaranteed by design.

CHARACTERIZATION PLOTS

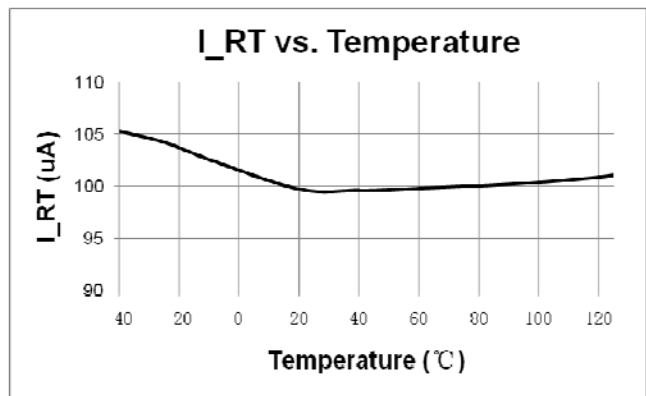
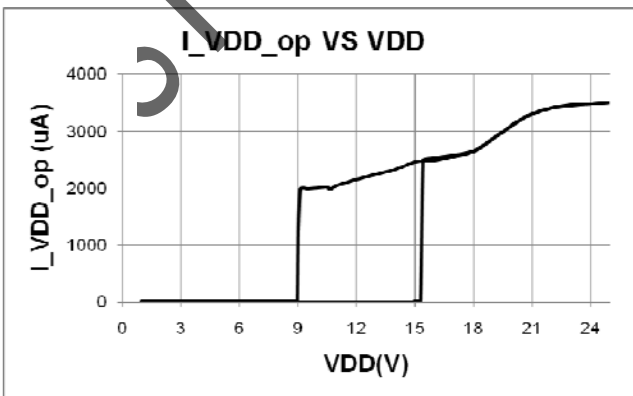
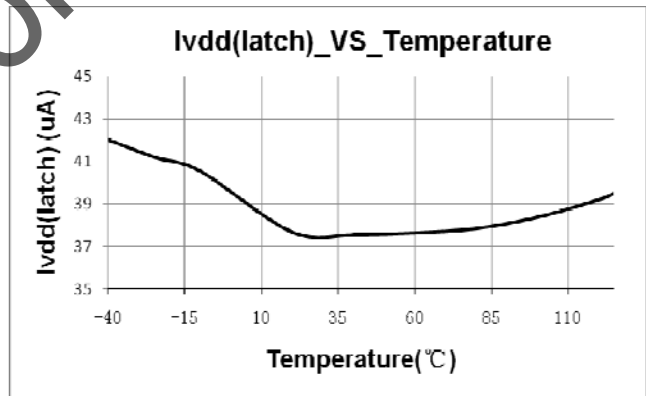
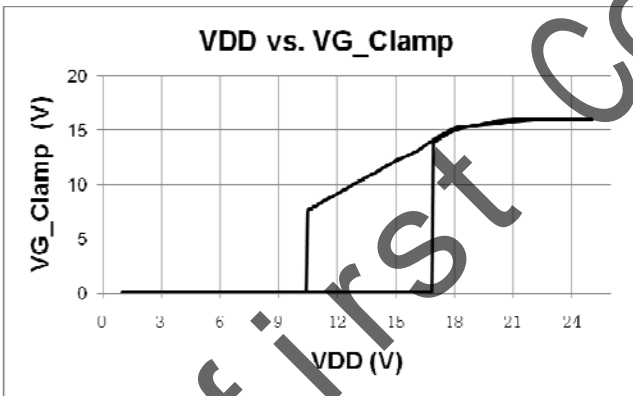
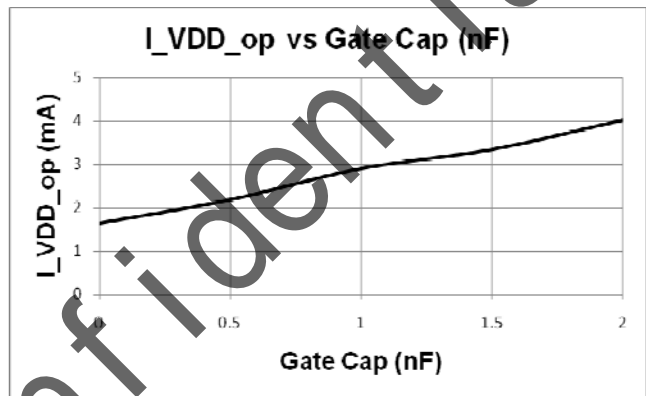
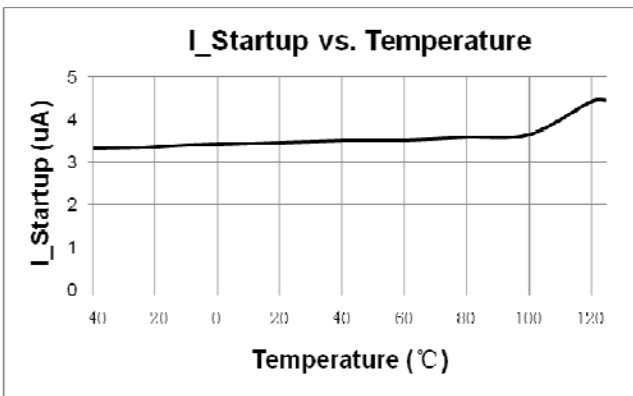
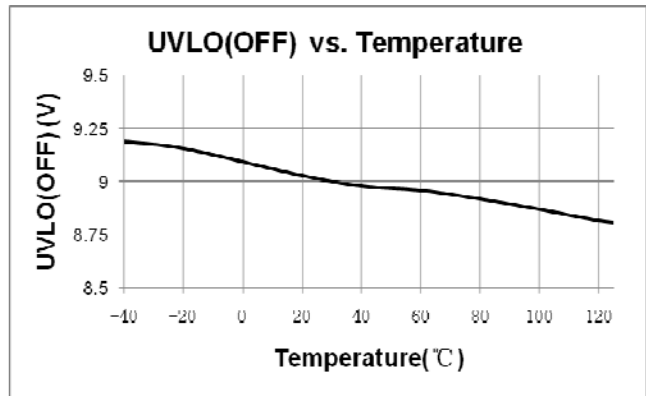
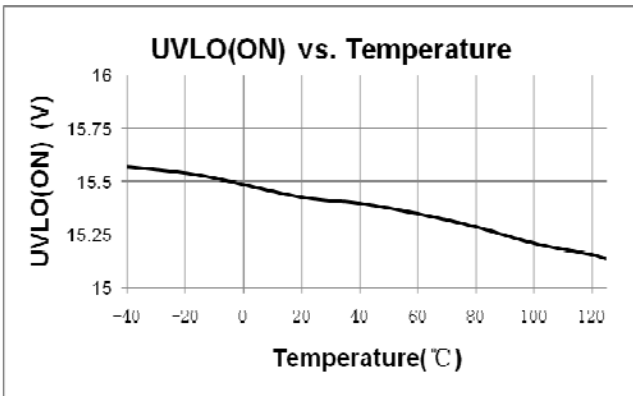

OPERATION DESCRIPTION

SF1585 is a high performance, low cost, highly integrated current mode PWM controller for medium to large offline flyback power converter applications. The built-in proprietary “Efficiency Equalization” with high level protection features improves the SMPS reliability and performance without increasing the system cost.

◆ **UVLO and Startup Operation**

Fig.1 shows a typical startup circuit. Before the IC begins switching operation, it consumes only startup current (typically 3uA) and current supplied through the startup resistor Rst charges the VDD hold-up capacitor Cdd. When VDD reaches UVLO turn-on voltage of 15.5V(typical), SF1585 begins switching and the IC current consumed increased to 2.7mA (typical). The hold-up capacitor Cdd continues to supply VDD before the energy can be delivered from auxiliary winding Na. During this process, VDD must not drop below UVLO turn-off voltage (typical 9V). The selection of Rst and Cdd should be a trade off between the power loss and startup time.

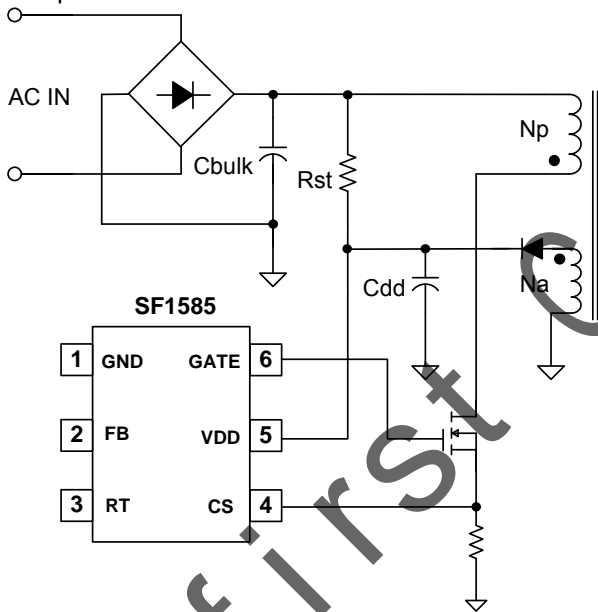

Fig.1

◆ **Low Operating Current**

The operating current in SF1585 is as small as 2.7mA (typical). The small operating current results in higher efficiency and reduces the VDD hold-up capacitance requirement.

◆ **Soft Start**

SF1585 features an internal 4ms (typical) soft start that slowly increases the threshold of cycle-by-cycle current limiting comparator during startup sequence. It helps to prevent transformer saturation and reduce the stress on the secondary diode during startup. Every restart attempt is followed by a soft start activation.

◆ **“Zero OCP/OPP Recovery Gap” Control**

The definition of OCP or OPP recovery gap of a power adaptor is illustrated in Fig.2. At T0, assuming an adaptor is at full loading mode. If the loading keeps increasing, then the system will output maximum power P_opp, which will trigger OPP protection at the same time. After the OPP protection is triggered, usually the system will enter into the auto-recovery mode, in burst manner. If the system power demand decreases below P_recovery, then system will enter into normal mode again, as shown in Fig.2. The difference between P_opp and P_recovery is defined as “**OPP Recovery Gap**”, which can cause system startup failure especially in 90VAC full load startup.

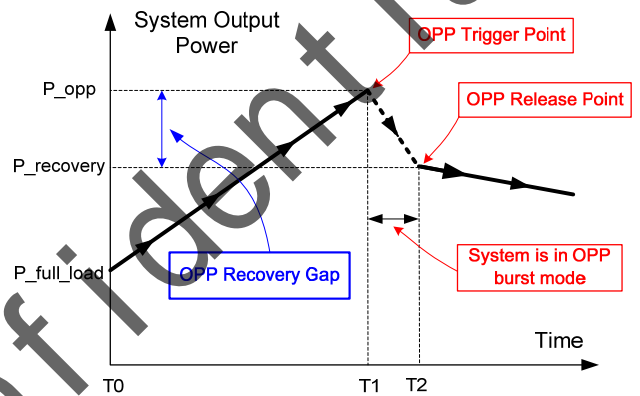

Fig.2

SF1585 can achieve “**Zero OCP/OPP Recovery Gap**” in the whole universal AC input range using SiFirst’s proprietary control algorithm.

◆ **800mA Drive Capability, up to 100W with Low System Cost**

SF1585 has a fast totem-pole gate driver with 800mA capability. It will enable the IC to be used in up to 100W applications with low system cost. The IC is also optimized to have no thermal issue when it is used in high power applications.

Cross conduction has been avoided to minimize heat dissipation, increase efficiency, and enhance reliability. An internal 16V clamp is added for MOSFET gate protection at higher than expected VDD input. A soft driving waveform is implemented to minimize EMI.

◆ **Synchronous Slope Compensation**

InSF1585, the synchronous slope compensation circuit is integrated by adding voltage ramp onto the current sense input voltage for PWM generation. This greatly improves the close loop stability at CCM and prevents the sub-harmonic oscillation and thus reduces the output ripple voltage.

◆ **65kHz Oscillator with Frequency Shuffling**

PWM switching frequency in SF1585 is fixed to 65kHz and is trimmed to tight range. To improve system EMI performance, SF1585 operates the system with $\pm 4\%$ frequency shuffling around setting frequency.

◆ **Proprietary η -Balance™ Control**

The efficiency requirement of power conversion is becoming tighter than before. These new energy standards focus on the average efficiency of the whole loading range. Therefore, the light load efficiency is becoming more and more important.

In SF1585 a proprietary η -Balance™ control is integrated to boost the light load efficiency. As shown in Fig.3, when the loading becomes light, the IC will reduce the PWM switching frequency according to an optimized frequency reduction curve. The specific frequency reduction curve and the power at a frequency are determined by the output of η -Balance™ control. For example, P1 is at full load, P2 is at 75% full load, P3 and P4 are 50% and 25% full load respectively. The η -Balance™ control can provide higher average efficiency than conventional frequency reduction technique, as illustrated in Fig.3

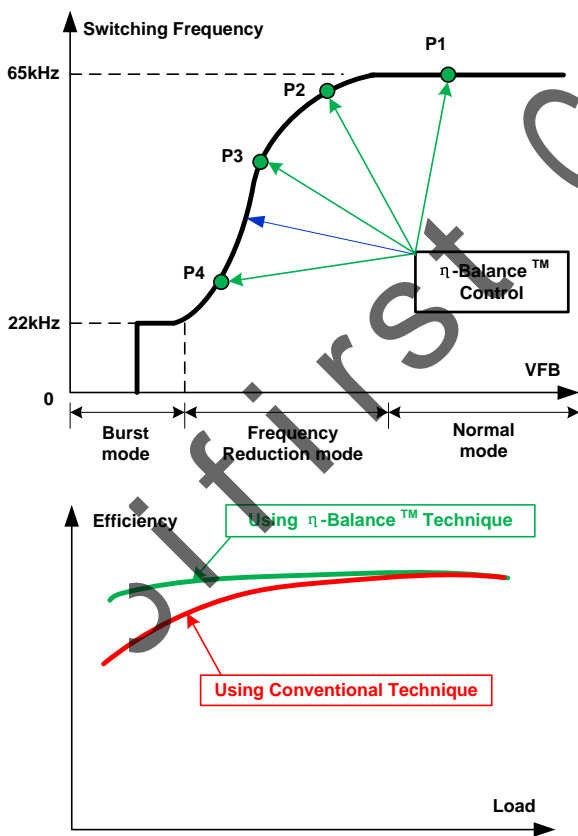

Fig.3

◆ **Burst Mode Control**

When the loading is very small, the system enters into burst mode. When VFB drops below V_{skip} ,

SF1585 will stop switching and output voltage starts to drop, which causes the VFB to rise. Once VFB rises above V_{skip} , switching resumes. Burst mode control alternately enables and disables switching, thereby reducing switching loss in standby mode.

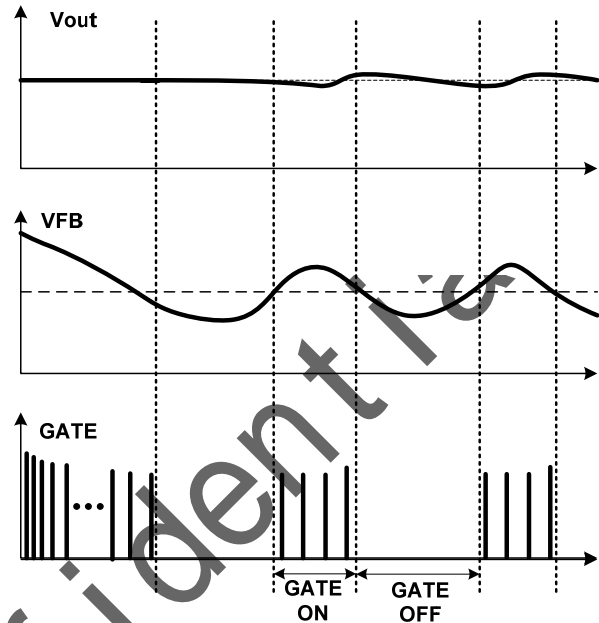

Fig.4

◆ **Audio Noise Free OCP Compensation**

Conventional OCP compensation may have audio noise issue when AC line is around 90VAC and heavy loading. As shown in Fig.5, when increasing from full load to hiccup load at 90VAC, VFB may oscillate in conventional OCP compensation system. The oscillation can generate large audio noise. In SF1585, a proprietary “Audio Noise Free OCP Compensation” is integrated, which can achieve constant power limiting with no audio noise generated.

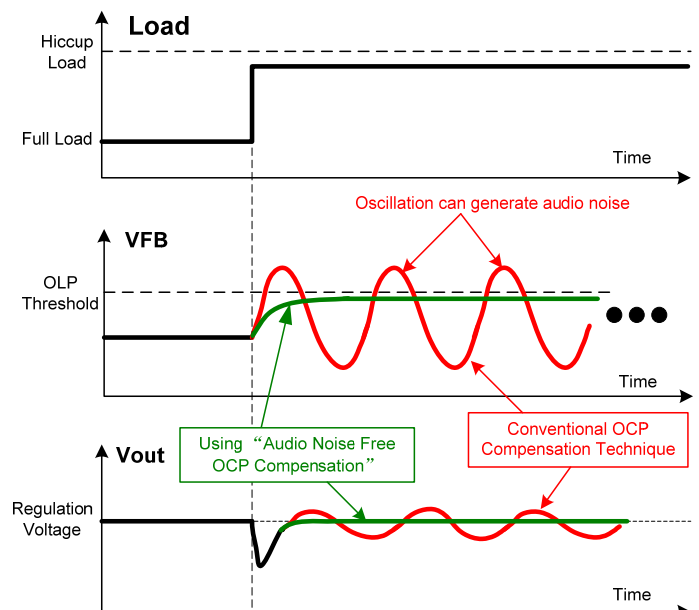

Fig.5

◆ **Leading Edge Blanking (LEB)**

Each time the power MOSFET is switched on, a turn-on spike occurs across the sensing resistor. The spike is caused by primary side capacitance and secondary side rectifier reverse recovery. To avoid premature termination of the switching pulse, an internal leading edge blanking circuit is built in. During this blanking period (250ns, typical), the PWM comparator is disabled and cannot switch off the gate driver. Thus, external RC filter with a small time constant is enough for current sensing.

◆ **Auto Recovery Mode Protection**

As shown in Fig.6, once a fault condition is detected, switching will stop. This will cause VDD to fall because no power is delivered from the auxiliary winding. When VDD falls to UVLO(OFF) (typical 9V), the protection is reset and the operating current reduces to the startup current, which causes VDD to rise, as shown in Fig.6. However, if the fault still exists, the system will experience the above mentioned process. If the fault has gone, the system resumes normal operation. In this manner, the auto restart can alternatively enable and disable the switching until the fault condition is disappeared.

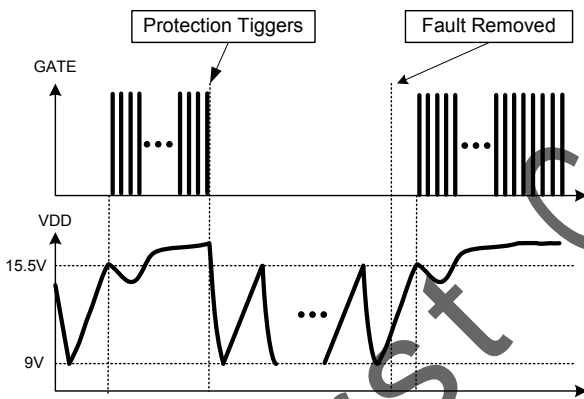

Fig.6

◆ **Over Load Protection (OLP) / Over Current Protection (OCP) / Over Power Protection (OPP) / Open Loop Protection (OLP)**

When OLP/OCP/OPP/Open Loop occurs, a fault is detected. If this fault is present for more than 82ms (typical), the protection will be triggered, the IC will experience an auto-recovery mode protection as mentioned above, as shown in Fig.7. The 82ms delay time is to prevent the false trigger from the power-on and turn-off transient.

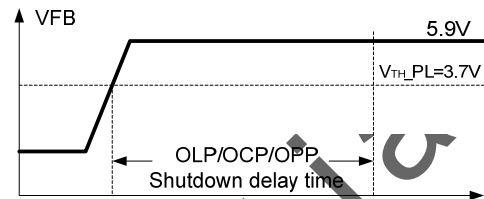
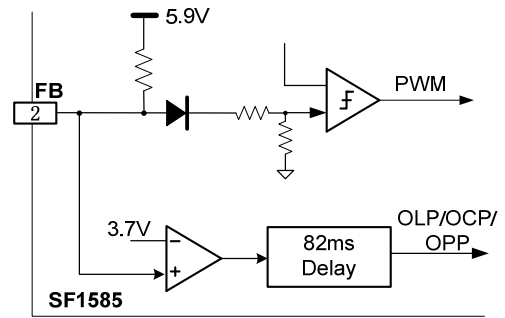

Fig.7

◆ **Over Temperature Protection with Latch Shutdown**

By connecting a NTC resistor in series with a regular resistor between RT and GND, the over temperature protection (OTP) can be realized. NTC resistor value becomes lower when the ambient temperature rises. With the fixed internal current I_{RT} flowing through the resistors, the voltage at RT pin becomes lower at high temperature. The internal OTP comparator is triggered and shut down the PWM signal when the sensed input voltage is lower than the comparator threshold voltage. OTP is a **latched shutdown** mode.

◆ **VDD OVP(Over Voltage Protection) with Latch Shutdown**

VDD OVP (Over Voltage Protection) is implemented in SF1585 and it is a protection of **latch shutdown** mode.

◆ **RT Pin Used as Latch Shutdown Input Control**

RT pin can also be used as a control input to implement system latch shutdown function. By externally forcing a level on pin RT less than 1.0V (typical), SF1585 can be permanently latched off. To resume normal operation, VDD voltage should go below 6V (typical), which implies to unplug the SMPS from the mains.

◆ **Pins Floating Protection**

In SF1585, if pin floating situation occurs, the protection is triggered immediately and the system will experience the process of auto-recovery mode protection.

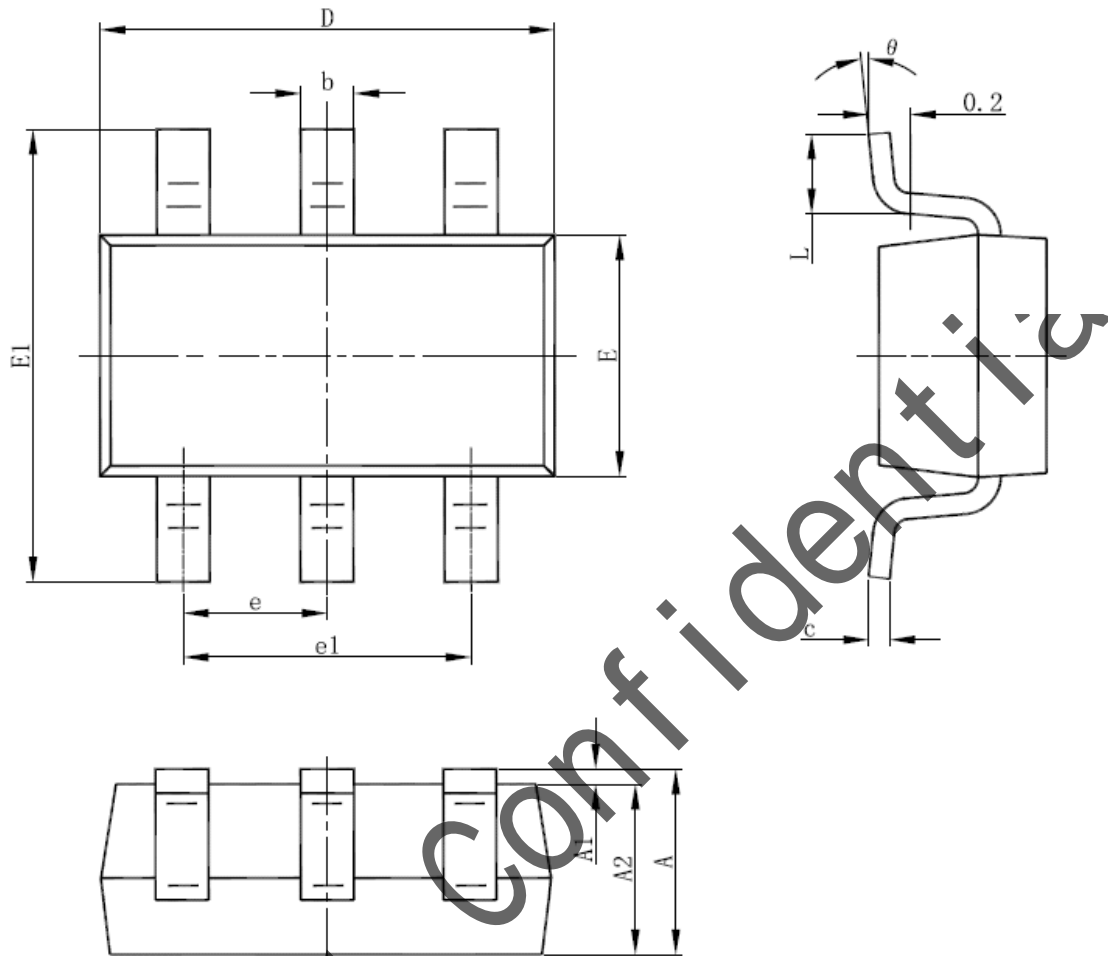
PACKAGE MECHANICAL DATA
SOT-23-6L PACKAGE OUTLINE DIMENSIONS

Symbol	Dimensions In Millimeters		Dimensions In Inches	
	Min	Max	Min	Max
A	1.000	1.300	0.039	0.051
A1	0.000	0.150	0.000	0.006
A2	1.000	1.200	0.039	0.047
b	0.300	0.500	0.012	0.020
c	0.100	0.200	0.004	0.008
D	2.800	3.020	0.110	0.119
E	1.500	1.700	0.059	0.067
E1	2.600	3.000	0.102	0.118
e	0.950 (BSC)		0.037 (BSC)	
e1	1.800	2.000	0.071	0.079
L	0.300	0.600	0.012	0.024
theta	0°	8°	0°	8°

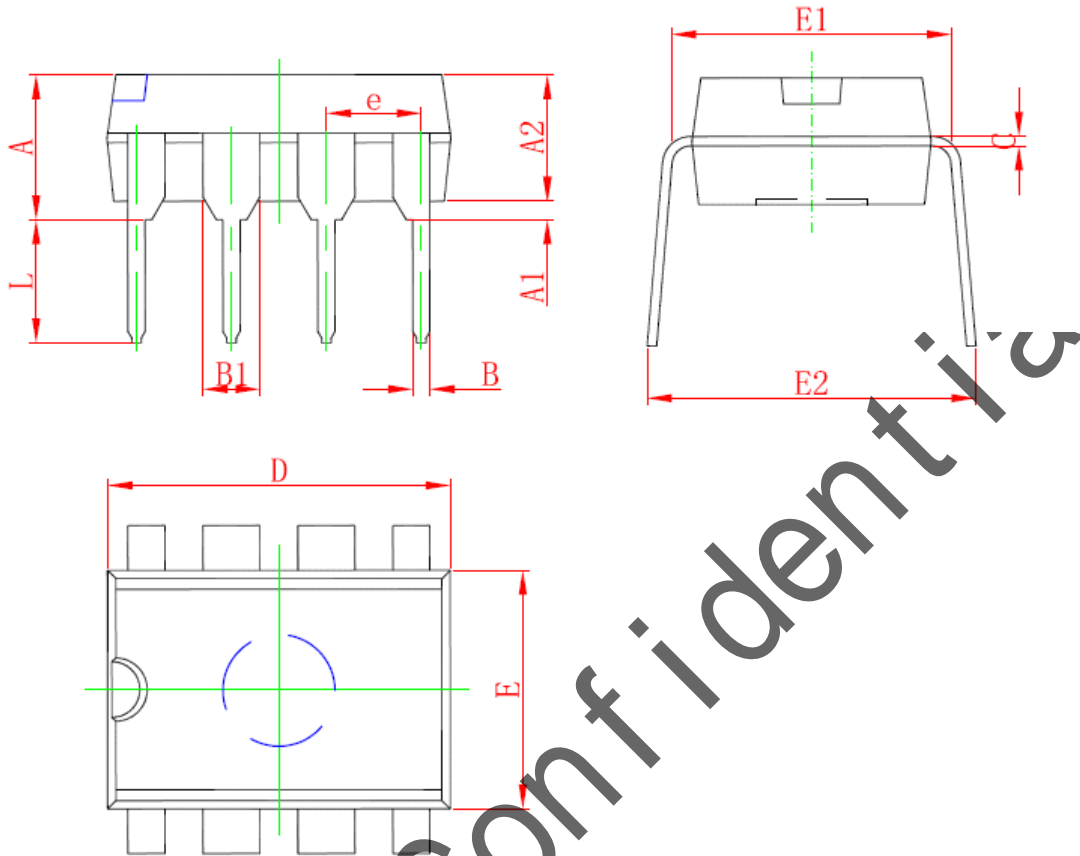
DIP8 PACKAGE OUTLINE DIMENSIONS

Symbol	Dimensions In Millimeters		Dimensions In Inches	
	Min	Max	Min	Max
A	3.710	4.310	0.146	0.170
A1	0.510		0.020	
A2	3.200	3.600	0.126	0.142
B	0.380	0.570	0.015	0.022
B1	1.524 (BSC)		0.06 (BSC)	
C	0.204	0.360	0.008	0.014
D	9.000	9.400	0.354	0.370
E	6.200	6.600	0.244	0.260
E1	7.320	7.920	0.288	0.312
e	2.540 (BSC)		0.100 (BSC)	
L	3.000	3.600	0.118	0.142
E2	8.400	9.000	0.331	0.354

IMPORTANT NOTICE

SiFirst Technology Nanhai, Ltd (SiFirst) reserves the right to make corrections, modifications, enhancements, improvements and other changes to its products and services at any time and to discontinue any product or service without notice. Customers should obtain the latest relevant information before placing orders and should verify that such information is current and complete.

SiFirst warrants performance of its hardware products to the specifications applicable at the time of sale in accordance with SiFirst's standard warranty. Testing and other quality control techniques are used to the extent SiFirst deems necessary to support this warranty. Except where mandated by government requirements, testing of all parameters of each product is not necessarily performed.

SiFirst assumes no liability for application assistance or customer product design. Customers are responsible for their products and applications using SiFirst's components. To minimize the risks associated with customer products and applications, customers should provide adequate design and operating safeguards.

Reproduction of SiFirst's information in SiFirst's data books or data sheets is permissible only if reproduction is without alteration and is accompanied by all associated warranties, conditions, limitations, and notices. Reproduction of this information with alteration is an unfair and deceptive business practice. SiFirst is not responsible or liable for such altered documentation. Information of third parties may be subject to additional restrictions.

Resale of SiFirst's products or services with statements different from or beyond the parameters stated by SiFirst for that product or service voids all express and any implied warranties for the associated SiFirst's product or service and is an unfair and deceptive business practice. SiFirst is not responsible or liable for any such statements.

SiFirst's products are neither designed nor intended for use in military applications. SiFirst will not be held liable for any damages or claims resulting from the use of its products in military applications.

SiFirst's products are not designed to be used as components in devices intended to support or sustain human life. SiFirst will not be held liable for any damages or claims resulting from the use of its products in medical applications.

SiFirst Confidential